

# SANCOM

**SA-PAN013018-P46****1.3-1.8 GHz High Power GaN-HEMT**

## Features

Frequency Range: 1.35-1.8 GHz

$P_{\text{sat}}$ :  $\geq 46$  dBm

Power Gain:  $\geq 12$  dB

Efficiency: = 50% (Type)

$Z_{\text{in}}/ Z_{\text{out}} = 50 \Omega$



## Description

Sancom Electric's GaN-HEMT SA-PAN013018-P46 offers high power, high efficiency, ease of matching and greater consistency for high power applications with 28V operation. The SA-PAN013018-P46 typically provides 46 dBm of saturated output power and 12 dB of large-signal gain and can be widely used in various RF/microwave systems.

### ABSOLUTE MAXIMUM RATINGS

Parameter	Symbol	Condition	Rating	Unit
Drain-Source Voltage	$V_{DS}$	TC=25°C	40	V
Gate-Source Voltage	$V_{GS}$	TC=25°C	-5	V
Storage Temperature	$T_{stg}$	TC=25°C	-65 to 150	°C
Channel Temperature	$T_{ch}$	TC=25°C	150	°C

### ELECTRICAL SPECIFICATIONS

Parameter	Symbol	Condition	Min	Typ	Max	Unit
Drain-Source Current	$I_{DS}$	$V_{DS}: 28\text{ V}$ CW (Continuous Wave) $P_{in}: 34\text{ dBm}$ Freq: 1.35 ~ 1.8 GHz	-	2.8	-	A
Saturated Power	$P_{sat}$		46	-	-	dBm
Power Gain	$G_p$		12	-	-	dB
Efficiency	$\eta$		-	50	-	%
Flatness	$\Delta G$		-0.8	-	0.8	dB

## Performance Plots

### Saturated Power VS Frequency

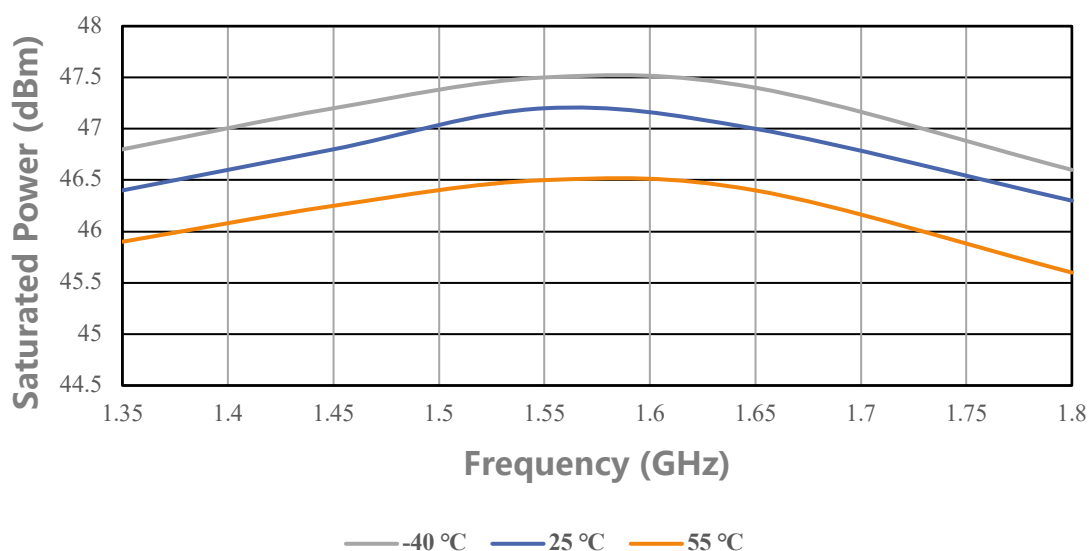

### Efficiency VS Frequency

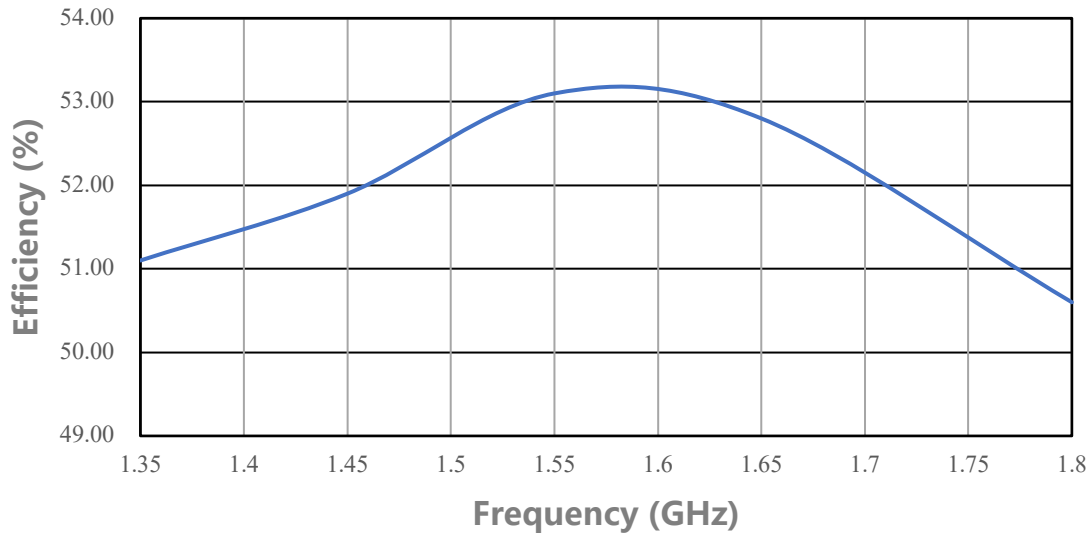

### Power Gain VS Frequency

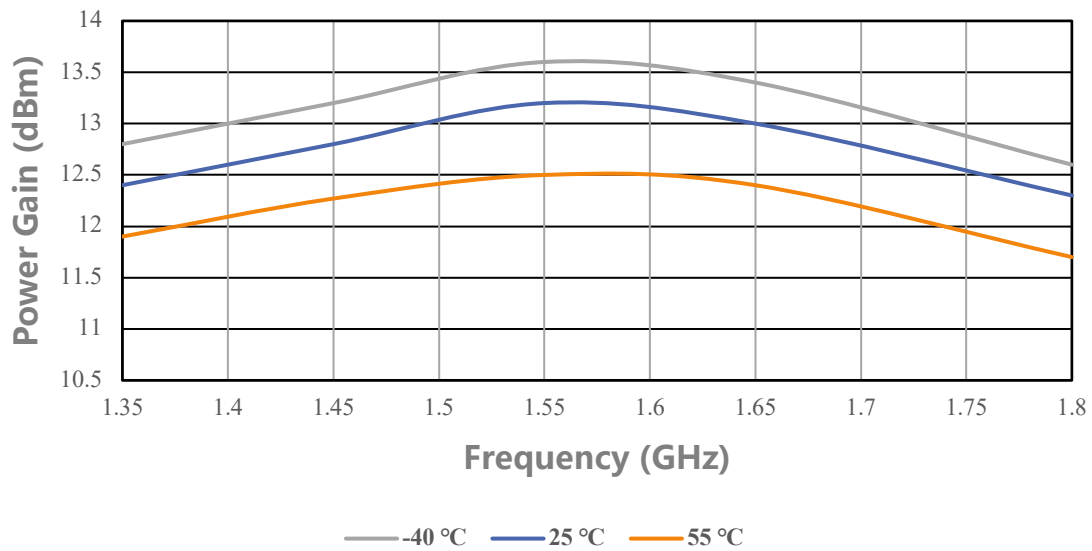

## Simplified Block Diagram

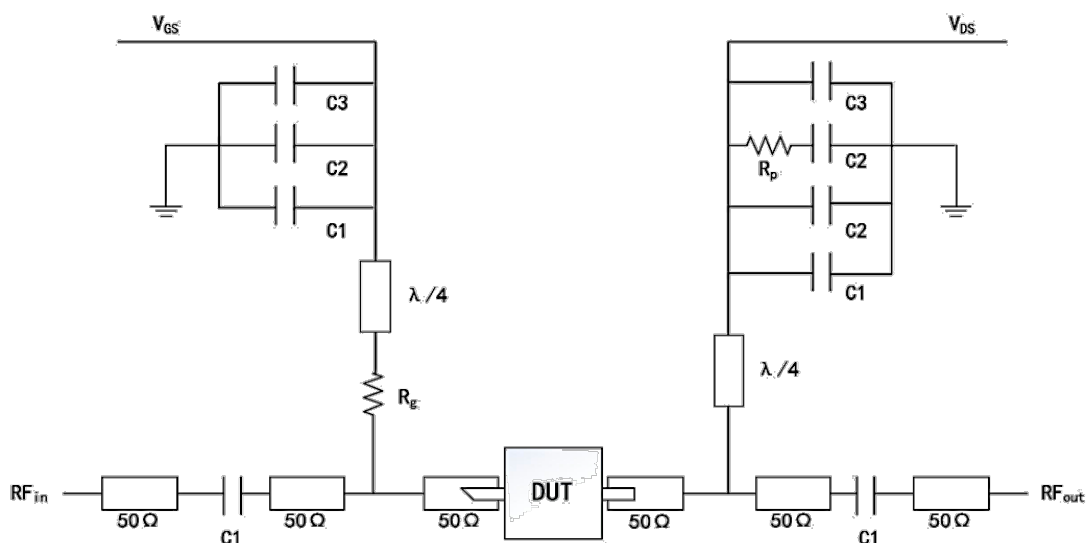

DUT information	
C1: 20 pF	Rp: 51 Ω
C2: 1000 pF	Rg: 15 Ω
C3: 100 μF	

## ESD Protection

ESD	Class III	2000 V
-----	-----------	--------

## Outline Drawing

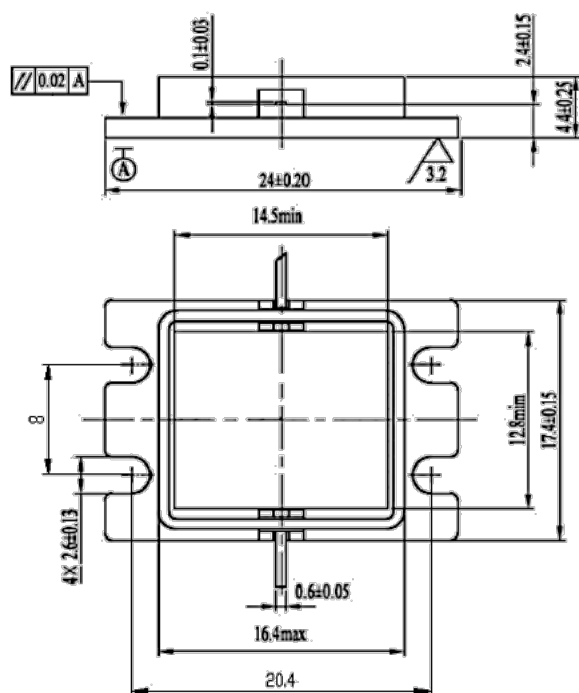

Unit: mm

## Attention

- Please keep away from moisture during transportation and storage
- Pay attention to ESD prevention during chip use and assembly. Wear a grounding ESD bracelet.
- When adding electricity, add gate electricity first and then add leakage electricity